

VBI Data Inserter

- Inserts data into SDV
- Bypass relay
- Ideal for Analogue VBI systems
- Multiple Analogue input capability
- Advanced syncs output

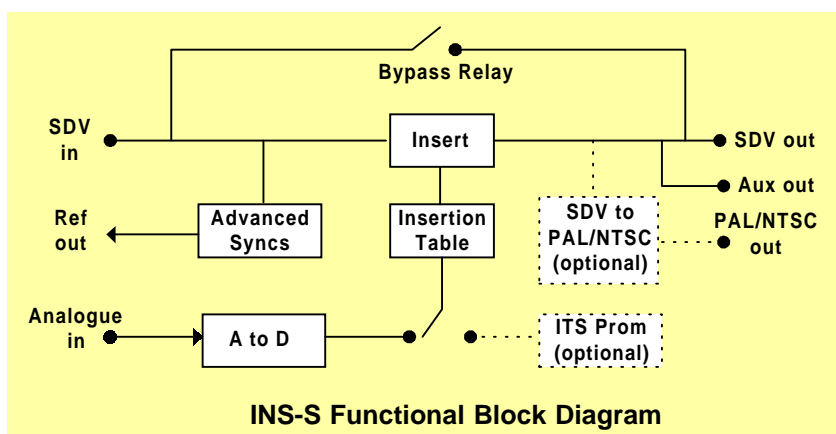

The INS-S VBI Data inserter provides a means of adding analogue VBI signals into a serial digital video signal, this allows existing analogue VBI generation equipment to continue to be used in digital systems. It has a Y only analogue to digital converter to allow the analogue VBI signal to be inserted into the selected lines of the serial digital video signal. An advanced syncs output is provided, timed to the digital input, to synchronise the analogue signal source to the digital data stream. The Inserter must be programmed with information about which lines to insert the VBI data onto, this is done at the time of manufacture with the insertion table stored in an EPROM. To change the setup the user can order 'POD', this is a small hand held programming device which plugs into the rear of the unit. Option -FP provides a front panel to allow easy the setup and change of the inserter.



Specifications:

Inputs:

Program 1 x BNC. SDV 270Mb/s to EBU tech 3267, SMPTE 259M.
VBI Data, Y 1 x BNC. Analogue composite PAL/NTSC 1 v p-p into 75R. Y only sampling with full spec CCIR601 filters.

Outputs:

Program 1 x BNC. SDV 270Mb/s to EBU tech 3267, SMPTE 259M with power fail bypass relay.
AUX 1 x BNC. SDV 270Mb/s to EBU tech 3267, SMPTE 259M.
Mon 1 x BNC. Analogue composite PAL/NTSC 1v p-p into 75R.
Syncs 1 x BNC. Analogue advanced syncs & black, 0.3v or 2v. Timing range 0-1us in 74ns steps.

Control:

GPI 1 x 9 way male 'D' for bypass or for special applications.
POD 1 x 9 way male 'D' for programming insertion table using POD if no front panel.

Physical:

19" rackmounting 1U case, 400mm deep.

Ordering Information:

INS-S Digital VBI inserter with analogue input, blank front panel.

Options:

-FP Front panel control & programming.
-ITS Insertion Test Signals, UK or CCIR.
-MON Analogue PAL/NTSC output for monitoring.
-2IP Two analogue inputs.
-4IP Four analogue inputs.
-NOAN No analogue input, inserter may be used for blanking or ITS only.
-B Asynchronous SDV data input.
-DM Dual IEC mains inlet & transformer for dual mains operation.
POD-INS Hand held programming module.

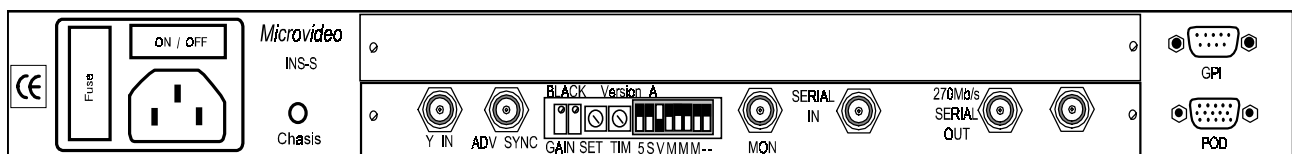

INS-S Rear Panel

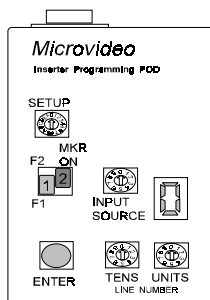

POD-INS