

Audio Mixer Module

- Four AES digital audio inputs
- Mixes two AES digital audio streams
- Analogue voice over input
- Analogue Output
- 24 bit audio processing

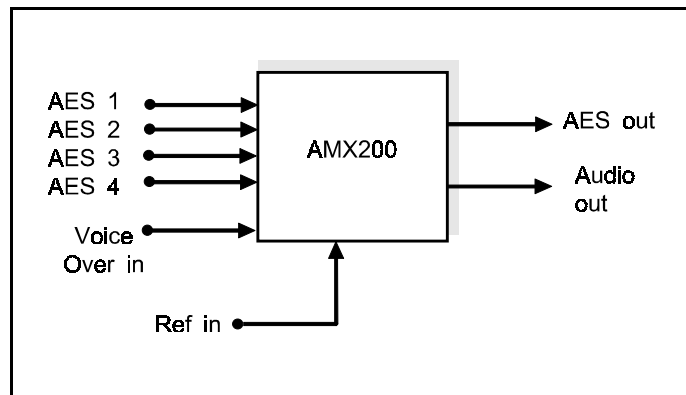

The AMX200 allows switching, mixing and cross-fading of AES digital audio sources. Its compact size allows multiple channels to be put into a single frame. It can be used with Microvideo's KEY200 digital video mixer module, allowing a single box solution for audio - video mixing. Additional features include an analogue input, for voice over applications, and an analogue output for monitoring. As part of the Series 200 range it can also be used with the MUX200 and DMX200 cards to allow handling of embedded audio.

The AMX200 audio mixer can be controlled by GPI triggers to activate the audio cuts and fades. With an additional CPU card fitted in the frame it can be controlled remotely from one of our control panels or by an automation system using RS232 / RS422.

Specifications

Digital Audio Inputs/Outputs

24 or 20 bit AES/EBU as described in EBU Tech 3250-E (or AES-3-1992), with 48Khz sample rate.
Standard AMX200 module uses balanced AES input/output through 15 way D-types.
(Single Ended AES using BNC's can be provided as an option).

Analogue Input / Outputs

Stereo Balanced Line Level through 15 Way D-types,
Conversion is performed by 128x oversampling.

Timing Reference Inputs

Analogue Video Reference, for standard 1V Black and Burst into 75R, internally terminated
TTL Level with Line Clock Timing (for use with Microvideo MUX200 embedder)
Alternatively the reference timing for the module may be taken from AES1 or AES4

Rear Panel for AMX200 with balanced AES/EBU interfaces.

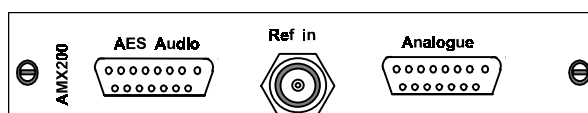

Product Codes

AMX200 Digital Audio Mixer Module with balanced AES inputs
AMX200U Digital Audio Mixer Module with unbalanced inputs(contact Microvide for more details)

Operation

The heart of the card is a Digital Signal Processor (DSP). This is designed to perform the complex high speed processing tasks that are required for digital audio manipulation. It is a fully programmable device and so can be made to perform a variety of different tasks.

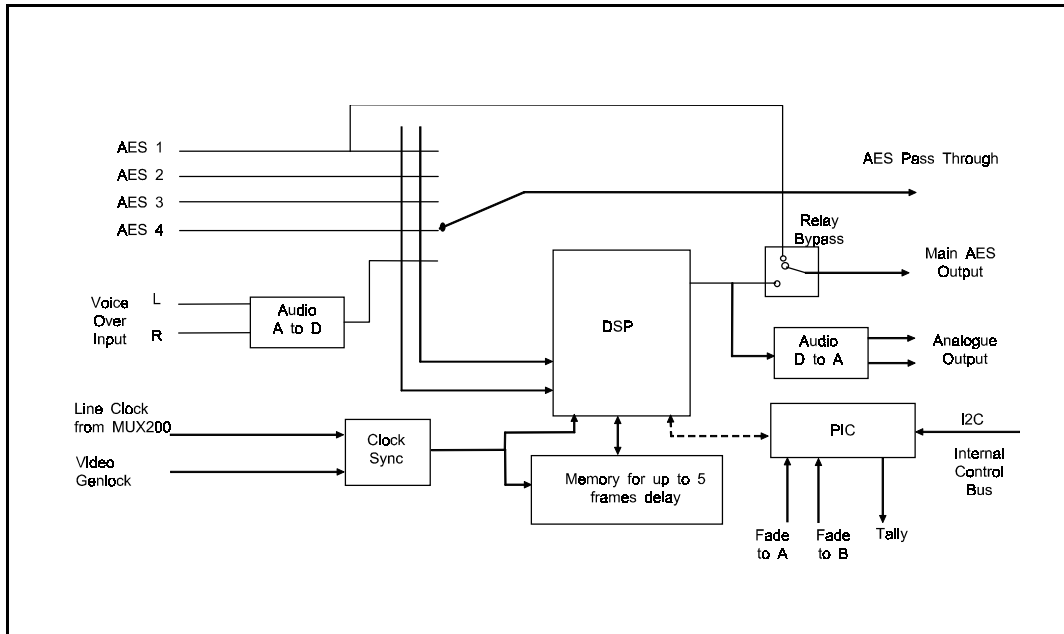

Control and Operation

DIP switches

With the Standard software (ver 1.0) the following parameters can be set by Dip switches.

Up

Sync from AES1 (or AES4)
625
Fade
Process
A - B mix
Normal Op
20 bit data output
Normal Op

Down

External Sync Input
525
Cut
Bypass (passive relay)
A - Analogue In Mix
Mix to silence
24 bit data output
1KHz Test Tone Output

GPI inputs

GPI Inputs allow simple control of the card, enabling Fade up / Fade Down to be activated. Tally Output indicates whether it is faded to A or B.

CPU card

A CPU Card mounted in the frame allows control from an automation system or one of our control panels. The following additional parameters can then be set remotely -

- Input Source for Mix** - AES1, AES2, AES3, AES4, Analogue Input or Silence.
- Set Fade Rate** - from 0 to 5 seconds.
- Adjust Level** - of Input or Output Audio.
- Add Delay** - to Input or Output Audio from 0 to 600ms (15 Frames).

One control Panel can be used to set all the cards in a frame or with our REM-6 panel, up to six different frames can be configured.

Applications for the AMX200

1) Multi-channel with GPI control

Ideal for simple cross fading from one source to another. Default setting for the AMX200 enable cross fading or cutting between AES1 and AES2. Dip switches on the board allow each card to be set to fade to silence or to the analogue input when GPI's are activated.

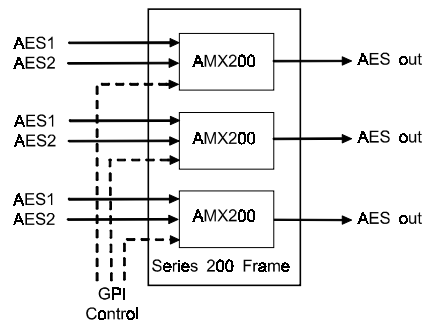

2) Multi-channel with Remote Control

The CPU card in the frame allows the user to configure any of the AMX200 modules. Here we show AES1 and AES2 but the user can change the fade source to any of the AES inputs, silence or the analogue input. They can also set gain levels and fade rates from the remote panel. The GPI's can still be used to initiate the fade or alternatively an automation system may use RS232 or RS422 to control the AMX200 modules.

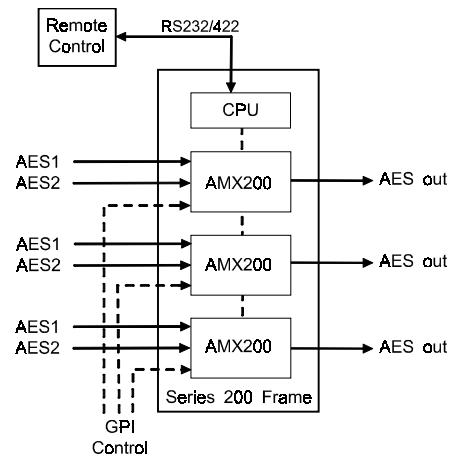

3) Audio and Video Mixing

Using the KEY200 digital video keyer-mixer module in the same frame enables mixing of audio and video. The control of the Key200 can be combined with the AMX200 achieving synchronous control. This allows the audio and video fades to be performed together or separately with fully programmable fade times.

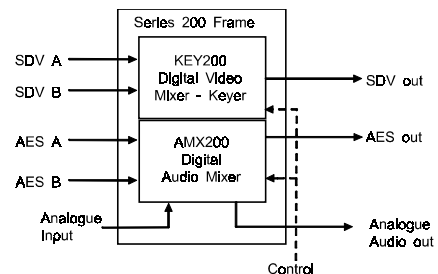

4) Embedded Audio

Using our embedded audio modules a solution can be built to process embedded audio. This may be full mixing and voice over insertion (as shown) or just audio processing to make gain and timing adjustments.

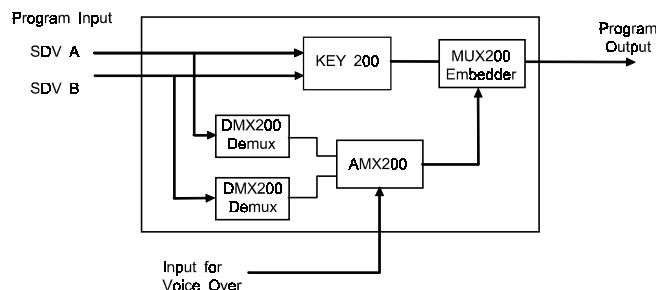

Above are just a few examples of systems that can be offered built around our AMX200. The modular approach we offer allows broadcasters to have a cost effective solution which exactly matches their requirements. Contact us with your system specification and we will provide a detailed proposal.