

AES200

Analogue audio to AES converter

INSERTERS

SWITCHES

CONVERSION

KEYERS

MIXERS

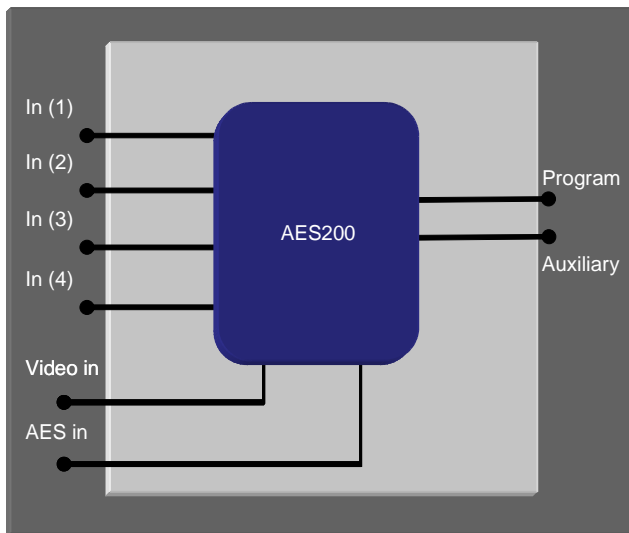

20 bit resolution

48KHz sample rate

Analogue video or AES reference



The AES200 is designed to convert analogue audio into AES/EBU digital audio. It handles four channels of analogue audio, converting them into two AES/EBU streams. The conversion is performed to 20 bit resolution with a 48KHz sample rate. The sample clock can be locked to either another AES digital audio stream or an analogue video source.

The AES200 is part of our Series 200 range of interface products. These can be mounted in a 1U or 3U frame. If the AES200 is used with Microvideo's MUX200 audio embedder the AES200 does not require an external sync reference, the reference can be provided by the MUX200 card.

MicroVideo

Copley Hill Farm
Babraham
Cambridge
England, CB22 3GN
t: +44 (0) 1223 834119
f: +44 (0) 1223 834471
w: www.microvideo.co.uk

AES200

Technical Information

INSERTERS

SWITCHES

CONVERSION

KEYERS

MIXERS

Inputs:	Audio	4 x differential, line level, analogue inputs. Impedance 15K
	Reference Video	Analogue video with sync. 625 or 525 line. This can be internally terminated or left unterminated for passive T-looping arrangements.
	Reference AES	Standard AES/EBU digital audio Note - When using AES200 with an embedder the reference input, whether video or AES, must be locked/derived from the SDV you are embedding into.
Outputs:	2 x AES/EBU digital audio as described in EBU Tech 3250-E (or AES-3-1992)	
Control:	DIP switches set	Video line standard 625/525 or auto detect Video reference or AES. (In absence it will free run) Channel status bits for - no emphasis, 50/15 emphasis, CCiTT J.17 emphasis and Stereo or 2 Channel mode
	LED's indicate	AES/EBU ref present Converter locked to video input
Specification:	Conversion is performed by 128x oversampling, to 20 bit resolution. THD+N -95dB approx Dynamic range 105dB approx Passband ripple 0.0025dB (20Hz - 21.7KHz) Stopband attenuation -85dB (26.3KHz)	
Physical:	Eurocard size module for mounting in our 1U or 3U frames.	
Power usage:	5W.	
Frames:	Up to 6 modules will fit in a Microvideo 1U frame and 15 in a 3U frame.	
Ordering:	AES200	Audio A to D, 4 x analogue audio in, 2 x AES out
	FR1U-20	1U rack mounting frame for series 200 cards (dual PSU)
	FR3U-10	3U rack mounting frame for series 200 cards (single PSU)
	FR3U-20	3U rack mounting frame for series 200 cards (dual PSU)
	-CB	Control Bus wiring for 3U frame

MicroVideo

Copley Hill Farm
Babraham
Cambridge
England, CB22 3GN
t: +44 (0) 1223 834119
f: +44 (0) 1223 834471
w: www.microvideo.co.uk